



4000 Series

4016TWG

Diesel Engine – Electro Unit

1002 kWm 1200 rev/min
1301 kWm 1500 rev/min



Economic power

Individual 4 valve cylinder heads give optimised gas flows, while unit fuel injectors ensure ultra fine fuel atomisation and hence controlled rapid combustion for efficiency and economy.

Commonality of components with other engines in 4000 Series family allows reduced parts stocking levels.

Reliable power

Developed and tested using latest engineering techniques.

Piston temperatures are controlled by an advanced gallery jet cooling system.

All engines are tolerant of a wide range of temperatures without derate.

Service is provided through the extensive Perkins network of over 4000 distributors and dealers worldwide.

Clean, efficient power

Exceptional power to weight ratio and compact size for easier transportation and installation.

Designed to provide excellent service access for ease of maintenance.

Engines designed to comply with major international standards.

Low gaseous emissions for cleaner operation.

The Perkins 4000 Series family of 8, 12 and 16 cylinder diesel engines was designed in advance of today's uncompromising demands within the power generation industry and includes superior performance and reliability.

The 4016TWG is a turbocharged air to water charge cooled, 16 cylinder vee form diesel engine. Its premium design and specification features provide economic and durable operation as well as exceptional power to weight ratio, improved serviceability, low gaseous emissions, overall performance and reliability essential to the power generation market.

Engine Speed (rev/min)	Type of Operation	Typical Generator Output (Net)		Engine Power			
		kVA	kWe	Gross		Net	
				kWm	bhp	kWm	bhp
1200	Baseload Power	858	687	771	1034	715	959
	Prime Power	1090	872	964	1293	908	1218
	Standby (maximum)	1202	962	1058	1418	1002	1344
1500	Baseload Power	1125	900	979	1313	937	1256
	Prime Power	1418	1135	1224	1641	1182	1585
	Standby (maximum)	1561	1249	1343	1801	1301	1745

The above ratings represent the engine performance capabilities within plus or minus 3% at the reference conditions equivalent to those specified in ISO 8528/1, ISO 3046/1, BS 5514/1.

Ratings conditions: 25°C air inlet temperature, barometer pressure 100 kPa, relative humidity 30%. Please consult your distributor or the factory for ratings in ambient conditions.

Note: For full ratings please refer to Perkins Engines Company Limited. All electrical ratings are based on an average alternator efficiency and a power factor of 0.8.

Fuel specification: BS 2869 Class A1 + A2 or ASTM D975 No 2D.

Rating Definitions

Baseload Power: Power available for continuous full load operation. No overload is permitted.

Prime Power: Power available for variable load with an average load factor not exceeding 80% of the prime power rating in any 24 hour period. Overload of 10% permitted for 1 hour in every 12 hours operation.

Standby (maximum): Power available at variable load in the event of a main power network failure for a maximum of 500 hours per year. No overload is permitted.

4000 Series

4016TWG

Standard Electro Unit Specification

Air inlet

- Mounted air filters and turbochargers – integral charge coolers

Fuel system

- Unit fuel injectors with lift pump and hand stop control
- Electronic governor to ISO 3046 Part 4 class A1
- Full-flow spin-on fuel oil filters

Lubrication system

- Wet sump with filler and dipstick
- Full-flow spin-on oil filters
- Engine jacket water/lub oil temperature stabiliser

Cooling system

- Twin gear driven circulating pumps
- Two twin thermostats
- Crankshaft pulley for fan drive

Electrical equipment

- 24 volt starter motor and 24 volt/40 amp alternator with integral regulator and DC output
- 24 volt combined high coolant temperature/low oil pressure switch
- Overspeed switch and magnetic pickup
- Turbine inlet temperature shutdown switch
- 24 volt stop solenoid (energised to run)

Flywheel and housing

- Flywheel to SAE J620 size 18
- SAE 00 flywheel housing

Optional Equipment

The following optional equipment is available to make up the specifications to Perkins ElectropaK specification:

Tropical radiator including: Water pipes, clips and hoses
Fan, fan guards and belts

Other optional extra equipment available

Twin heavy duty air cleaner – paper element with pre-cleaner
Changeover lubricating oil filters
Changeover fuel oil filters
Immersion heater with thermostat
Water pipes, clips and hoses for radiator
Air starters
Instrument panel

NB This list is not exhaustive, further options may be available to meet to particular applications on enquiry to Perkins Sales Department

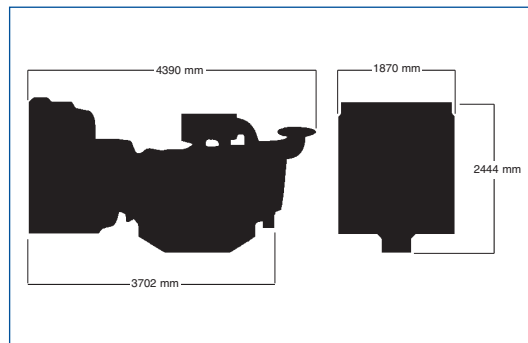

Fuel Consumption (g/kWh)		
Engine Speed	1200 rev/min	1500 rev/min
Standby Maximum Rating	209	208
Prime Power Rating	207	206
Baseload Power Rating	207	207
75% of Prime Power Rating	208	208
50% of Prime Power Rating	217	217
25% of Prime Power Rating	236	233

General Data

Number of cylinders	16	
Cylinder arrangement	60° Vee form	
Cycle	4 stroke	
Induction system	Turbocharged Air to water charge cooled	
Combustion system	Direct injection	
Cooling system	Water-cooled	
Displacement	61.123 litres	
Bore and stroke	160 x 190 mm	
Compression ratio	13.6:1	
Direction of rotation	Anti-clockwise, viewed from flywheel end	
Firing order	1A, 1B, 3A, 3B, 7A, 7B, 5A, 5B, 8A, 8B, 6A, 6B, 2A, 2B, 4A, 4B	
Total lubrication system capacity	237.2 litres	
	Electro Unit	ElectropaK
Total coolant capacity	95 litres	225 litres
Length	3289 mm	4390 mm
Width	1547 mm	1870 mm
Height	2128 mm	2444 mm
Total weight (dry)	5940 kg	6815 kg

Final weight and dimensions will depend on completed specification



Perkins Engines Company Limited

Peterborough PE1 5NA
United Kingdom
Telephone +44 (0)1733 583000
Fax +44 (0)1733 582240
www.perkins.com



Distributed by