

Generator Set

Diesel

KTA38 Series Engine

748kW - 1000kW 50Hz
837kW - 1020kW 60Hz



Description

This Cummins Power Generation commercial generator set is a fully integrated power generation system, providing optimum performance, reliability and versatility for stationary standby and prime applications.



This generator set is designed and manufactured in facilities certified to ISO9001.



This generator set is available with CE Certification.



The Prototype Test Support (PTS) program verifies the performance integrity of the generator set design. Cummins Power Generation products bearing the PTS symbol meet the prototype test requirements of NFPA 110 for Level 1 systems.

Features

- CE Listed Generator Set - The complete generator set assembly is available Listed to CE.
- Exhaust Emissions - Optional Engine certification to U.S. EPA Nonroad Source Emission Standards, CFR 40 on all 60 Hz models.
- Cummins® Heavy-Duty Engine - Rugged 4-cycle industrial diesel delivers reliable power, low emissions and fast response to load changes.
- Permanent Magnet Generator (PMG) - Offers enhanced motor starting and fault clearing short circuit capability.
- Alternator - Several alternator sizes Offer selectable motor starting capability with low reactance 2/3 pitch windings; low waveform distortion with non-linear loads, fault clearing short-circuit capability and class H insulation.
- Control System - The PowerCommand® electronic control is standard equipment and provides total genset system integration, including automatic remote starting/stopping, precise frequency and voltage regulation, alarm and status message display, AmpSentry protection, output metering, auto-shutdown at fault detection and NFPA 110 compliance.
- Cooling System - Standard integral set-mounted radiator system, designed and tested for rated ambient temperatures, simplifies facility design requirements for rejected heat.
- Structural Steel Skid Base - Robust skid base supports the engine, alternator and radiator.
- Warranty and Service - Backed by a comprehensive warranty and worldwide distributor network.

Model	Standby		Prime		Continuous		DataSheet	
	50 Hz	60 Hz	50 Hz	60 Hz	50 Hz	60 Hz	50 Hz	60 Hz
	kW (kVA)	kW (kVA)	kW (kVA)	kW (kVA)	kW (kVA)	kW (kVA)		
C825D5E	660 (825)	NA	600 (750)	NA	NA			
C900D5E	720 (900)	NA	656 (820)	NA	NA	NA		
C1000D5E	800 (1000)	NA	728 (910)	NA	NA	NA		
DFJC	832 (1040)	NA	748 (936)	NA	NA	NA		
DFJD	906 (1132)	NA	823 (1029)	NA	NA	NA		
C1250D5A	1000 (1250)	NA	900 (1125)	NA	NA	NA		

Generator Set Specifications

Governor Regulation Class	ISO8528
Voltage Regulation, No Load to Full Load	± 1%
Random Voltage Variation	± 1%
Frequency Regulation	Isochronous
Random Frequency Variation	±0.25%
Radio Frequency Emissions Compliance	IEC 801.2 through IEC 801.5; MIL STD 461C, Part 9

Engine Specifications

Design	4 cycle, in line, turbo Charged and after-cooled
Bore	159mm (6.25in.)
Stroke	159mm (6.25in.)
Displacement	38 litre (2300in. ³)
Cylinder Block	Twelve-cylinder vee formation, direct injection, four-cycle diesel engine
Battery Capacity	890 amps minimum at ambient temperature 32°F (0°C)
Battery Charging Alternator	55 amps
Starting Voltage	24-volt, negative ground
Fuel System	Direct injection
Fuel Filter	Dual spin on paper element fuel filters with standard water separator.
Air Cleaner Type	Dry replaceable element
Lube Oil Filter Type(s)	Spin-on paper element full flow and bypass lube oil filters.
Standard Cooling System	122°F (50°C) ambient radiator

Alternator Specifications

Design	Brushless, 4 pole, drip proof revolving field
Stator	2/3 pitch
Rotor	Direct coupled by flexible disc
Insulation System	Class H
Standard Temperature Rise	150°C Standby
Exciter Type	PMG (Permanent Magnet Generator)
Phase Rotation	A (U), B (V), C (W)
Alternator Cooling	Direct drive centrifugal blower fan
AC Waveform Total Harmonic Distortion	No load < 1.5%. Non distorting balanced linear load < 5%
Telephone Influence Factor (TIF)	<50 per NEMA MG1-22.43
Telephone Harmonic Factor (THF)	<3%

Available Voltages

50 Hz		60 Hz	
Line – Neutral / Line - Line		Line – Neutral / Line - Line	
110/190	240/416	110/190	230/380
115/200	255/440	115/200	240/416
120/208		120/208	255/440
127/220		127/220	277/480
220/380		139/240	347/600
230/400		220/380	

Note: Consult factory for other voltages.

Generator Set Options

Engine <ul style="list-style-type: none"> • Heavy duty air cleaner • Coolant heater and thermostat • Lead acid batteries • Sump drain pump • Oil and water drain taps • CE compliance (Guarding) Exhaust Temp monitoring (PCCP only) <ul style="list-style-type: none"> • Tool kit • Compliance TALuft Cooling <ul style="list-style-type: none"> • 50°C ambient radiator • Remote radiator cooling • Oil temperature indication 	Alternator <ul style="list-style-type: none"> • Anti-condensation heater • Thermistors Exhaust System <ul style="list-style-type: none"> • Industrial silencer • Residential silencer • Flexible exhaust & bellows Fuel System <ul style="list-style-type: none"> • Hand fuel transfer pump • Automatic Fuel transfer pump • Free-standing fuel tanks with stand • Fuel tank level switch 	<ul style="list-style-type: none"> • High fuel level warning • Low fuel level shutdown Generator Set <ul style="list-style-type: none"> • Weather protective enclosures • Silenced enclosures Control Panel <ul style="list-style-type: none"> • 3 or 4 pole Breaker • Battery Charger • CE compliance and PCC systems • Cable entrance box
--	---	---

Note: Some options may not be available on all models, consult factory for availability.

Control System

PowerCommand™ 3100 - Generator Set Control

Description

The PowerCommand™ 3100 Control is a microprocessor-based generator set monitoring, and control system. The control provides an operator interface to the genset, digital voltage regulation, digital governing and generator set protective functions.

The PowerCommand™ 3100 generator set control is suitable for use on a wide range of generator sets in non-paralleling and paralleling applications

The PowerCommand™ Control can be configured for any frequency, voltage and power connection configuration from 120 to 13,800 VAC for 50Hz or 60Hz operation.

Power for the control is derived from the generator set starting batteries. The control functions over a voltage range from 8VDC to 35VDC.

Major Features

- Digital Governing and Voltage Regulation, including digital overcurrent fault regulation.
- Digital Voltage Regulation with 3-phase sensing
- AmpSentry™ Protection for true alternator overcurrent protection.
- Analog and Digital AC Output Metering.
- Battery Monitoring System to sense and warn against a weak battery condition.
- Digital Alarm and Status Message Display
- Generator set Monitoring: Displays status of all critical engine and alternator generator set functions.
- Smart Starting Control System: Integrated fuel ramping to limit black smoke and frequency overshoot.
- Advanced Serviceability using InPower™, a PC-based software service tool.
- PowerCommand Network (optional) Provides LonMark interface to external devices

Control System

Includes all functions to locally or remotely start and stop, and protect the generator set.

Control Switch - RUN/OFF/AUTO

OFF Mode - the generator set is shut down and cannot be started

RUN mode the generator set will execute its start sequence

AUTO mode, the generator set can be started with a start signal from a remote device

LED Indicating Lamps - includes LED indicating lamps for the following functions:

- Not-in-Auto mode
- Common warning
- Shutdown
- Phase and Scale Indication

Fault Reset Switch. Allows the operator to reset the control after a warning or shutdown condition.

Emergency Stop Switch. Immediate shut down of the generator set on operation.

Base Engine Protection

- Overspeed Shutdown
- Low Oil Pressure Warning / Shutdown
- High Engine Temperature Warning / Shutdown
- Underspeed / Sensor Fail Shutdown
- Fail to Start / Fail to Crank
- Low / High Battery Voltage

Options

Integrated PowerCommand Digital Paralleling Controls

Key Type Mode Selector Switch

Exhaust Temperature Monitoring

PowerCommand Network

Refer to the PowerCommand Controls Technical Bulletin for detailed information (S1025C-Non-Paralleling / S1005c-Paralleling)



Ratings Definitions

Standby	Prime (Unlimited Running Time):	Base Load (Continuous):
Applicable for supplying emergency power for the duration of normal power interruption. No sustained overload capability is available for this rating. This rating is applicable to installations served by a reliable normal utility source. This rating is only applicable to variable loads with an average load factor of 80 percent of the standby rating for a maximum of 200 hours of operation per year and a maximum of 25 hours per year at 100% of its standby rating. The standby rating is only applicable to emergency and standby applications where the generator set serves as the back up to the normal utility source. No sustained utility parallel operation is permitted with this rating. (Equivalent to Fuel Stop Power in accordance with ISO3046, AS2789, DIN6271 and BS5514). Nominally Rated.	Applicable for supplying power in lieu of commercially purchased power. Prime power is the maximum power available at a variable load for an unlimited number of hours. A 10% overload capability is available for limited time. (Equivalent to Prime Power in accordance with ISO8528 and Overload Power in accordance with ISO3046, AS2789, DIN6271, and BS5514). This rating is not applicable to all generator set models.	Applicable for supplying power continuously to a constant load up to the full output rating for unlimited hours. No sustained overload capability is available for this rating. Consult authorized distributor for rating. (Equivalent to Continuous Power in accordance with ISO8528, ISO3046, AS2789, DIN6271, and BS5514). This rating is not applicable to all generator set models.

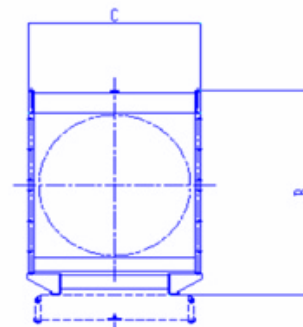
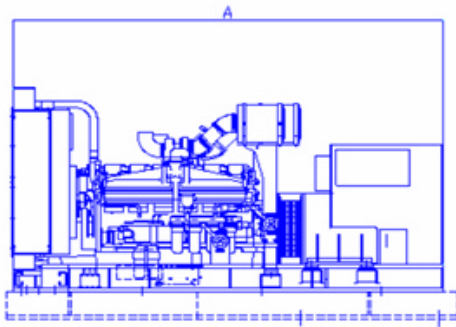

This outline drawing is to provide representative configuration details for model series only. Do not use for installation design, see respective model data sheet for specific outline drawing number.

Model	Dim "A" mm (in.)	Dim "B" mm (in.)	Dim "C" mm (in.)	Set Weight* Dry kg (lbs)	Set Weight* Wet kg (lbs)
C825D5E	4570	2540	1790	7640	8350
C900D5E	4570	2540	1790	7640	8350
C1000D5E	4570	2540	1790	7640	8350
DFJC	4570	2540	1790	7640	8350
DFJD	4570	2540	1790	7640	8350
C1250D5A	4570	2540	1790	7640	8350

*Note: Weights represent a set with standard features. See outline drawings for weights of other configurations. Weights are calculated using the largest alternator frame size.

See your distributor for more information.